

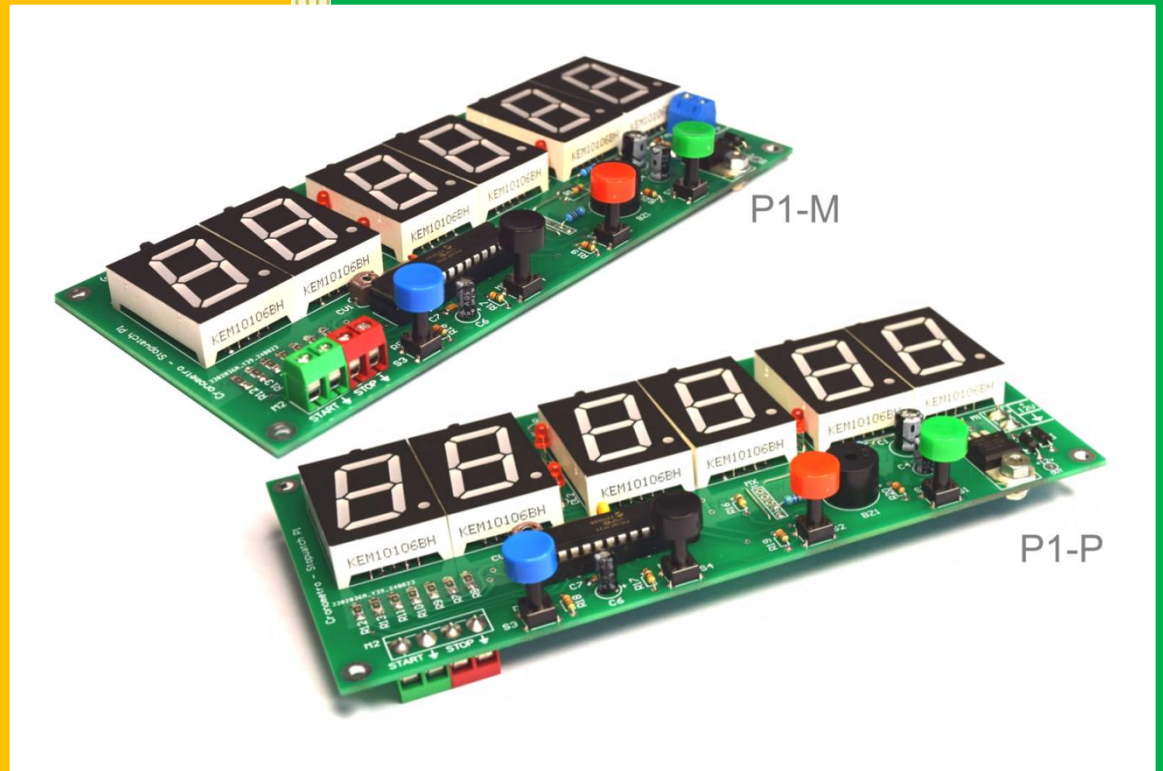

OWNER'S MANUAL

P1 DIGITAL STOPWATCH



P1

DIGITAL STOPWATCH

mm:ss.dd

(with 1" Display)

P1 FEATURES

- ❑ Power Supply: **12Vdc**.
- ❑ Management by a **Microchip PIC16F1933** microcontroller.
- ❑ **Quartz accuracy**.
- ❑ Range of measurement: fino a **59min 59sec 99cent**.
- ❑ Resolution: **0.01 s** (in 1/100 seconds).
- ❑ **Overflow** Indicator.
- ❑ Detection of **INTERMEDIATE** times.
- ❑ **4 operating mode**.
- ❑ **6 Display** (7 segment - 1" - Digit H25 mm.).
- ❑ 4 On Board command buttons: **START**, **STOP**, **RESET** and **MODE**.
- ❑ Screw terminal block for remote control of **START** and **STOP/INTERMEDIATE**.
- ❑ **User setting stored** in the microcontroller memory.
- ❑ Protection diode against **inversion polarity** of power supply.
- ❑ Easy to use.
- ❑ PCB dimensions: mm. **170 x 80**.

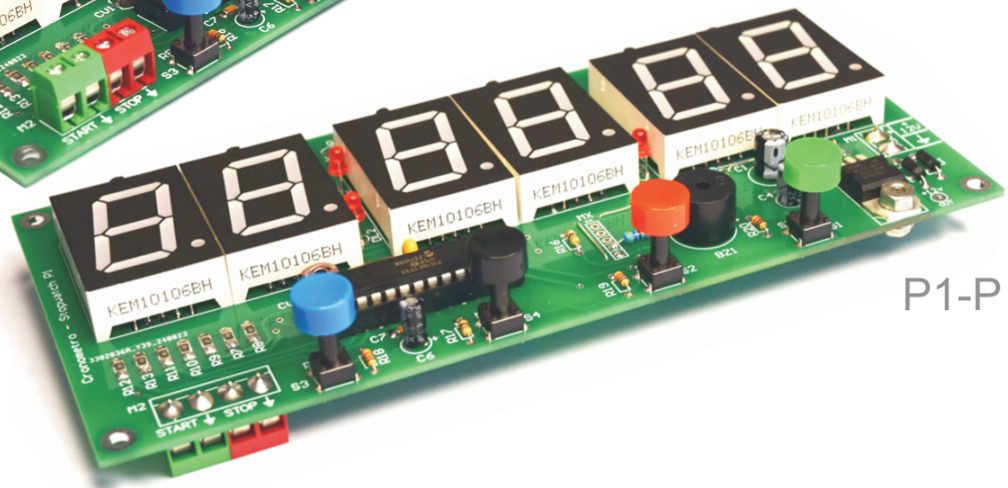
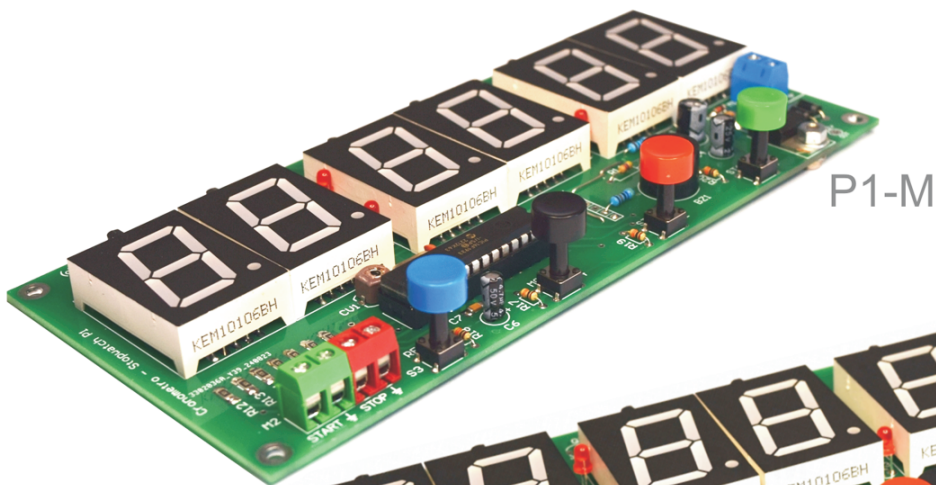

USER'S GUIDE

The P1 Digital Stopwatch can detect times up to "59:59.99" and the turning ON the small dot on the last display at the right, indicates that the count is **Overflow** and the count continues with dot on ("00:00.00. ").

The use of this stopwatch is very simple and intuitive.

- When power on, after the **TEST DISPLAY**, the stopwatch displays the value "00:00.00".
- **To start the count**, press the **START** button. The display shows the real time with a resolution of 1 hundredth of second.
- **With "Double command for START and STOP"** - **To take the intermediate times**, always press the **STOP** button. The intermediate time will be displayed on the display and it will "frozen" until the **MODE** button is pressed.
- **With "Single command for START/STOP"** - **To take the intermediate times**, always press the **START** button. The intermediate time will be displayed on the display and it will "frozen" until the **MODE** button is pressed.
- As told, to return in real-time counting, press the **MODE** button.
- **To reset the count**, press the **RESET** button: the display will return to ready and will show the value "00:00.00". The **RESET** button is active ONLY when an intermediate time is shown on the display: any press of the **RESET** button during the real-time count will have no effect.
- When the count exceeds the value "59:59.99" a small light dot will ON in the last display at the right and the stopwatch continues the count re-starting from "00:00.00." (the right light dot indicates an **Overflow**).

The stopwatch also can be managed remotely by means of actuators to be connected on the **START** and **STOP** terminal blocks (M2 socket): the contacts of the actuators must be **Normally Open (N.O.)** and the contacts closed will activate the stopwatch.

CHOICE OF OPERATING MODES

The P1 stopwatch can work by 4 different modes: two for **counting** and two for **commands**.

COUNTING MODE SELECTION

To set the **counting mode**, press and hold the **MODE** button and simultaneously press the **STOP** button.

Release the buttons when the first display at the right show the character "**C**" or "**r**" as specified below:



Continue count after each STOP

The character "**C**" indicates that after each STOP/INTERMEDIATE, the counting of the stopwatch continue and never restart to "**00:00.00**".



Reset count after each STOP

The character "**r**" indicates that after each STOP/INTERMEDIATE, the stopwatch count always restarts to "**00:00.00**".

COMMAND MODE SELECTION

To set the **command mode**, press and hold the **MODE** button and simultaneously press the **RESET** button.

Release the buttons when the first display at the left show the character "**d**" or "**S**" as specified below:



Double command for START and STOP

The character "**d**" indicates that the stopwatch works with the **START** button to start the count and the **STOP** button to take the stop or intermediate times.



Single command for START/STOP

The character "**S**" indicates that the stopwatch works ONLY with the **START** button (both for Start and for Stop/Intermediates). In this mode, the **STOP** button (and relative terminal block) has no effect.

The operating modes are saved in the memory of the chip (non-volatile settings) and for this reason, after each power ON, the stopwatch will always work with the last modes programmed by the user.

The two operating modes chosen by the user will be displayed each time the stopwatch is power on, immediately after the DISPLAY TEST.

P1 Stopwatch - Terminal Blocks and Commands

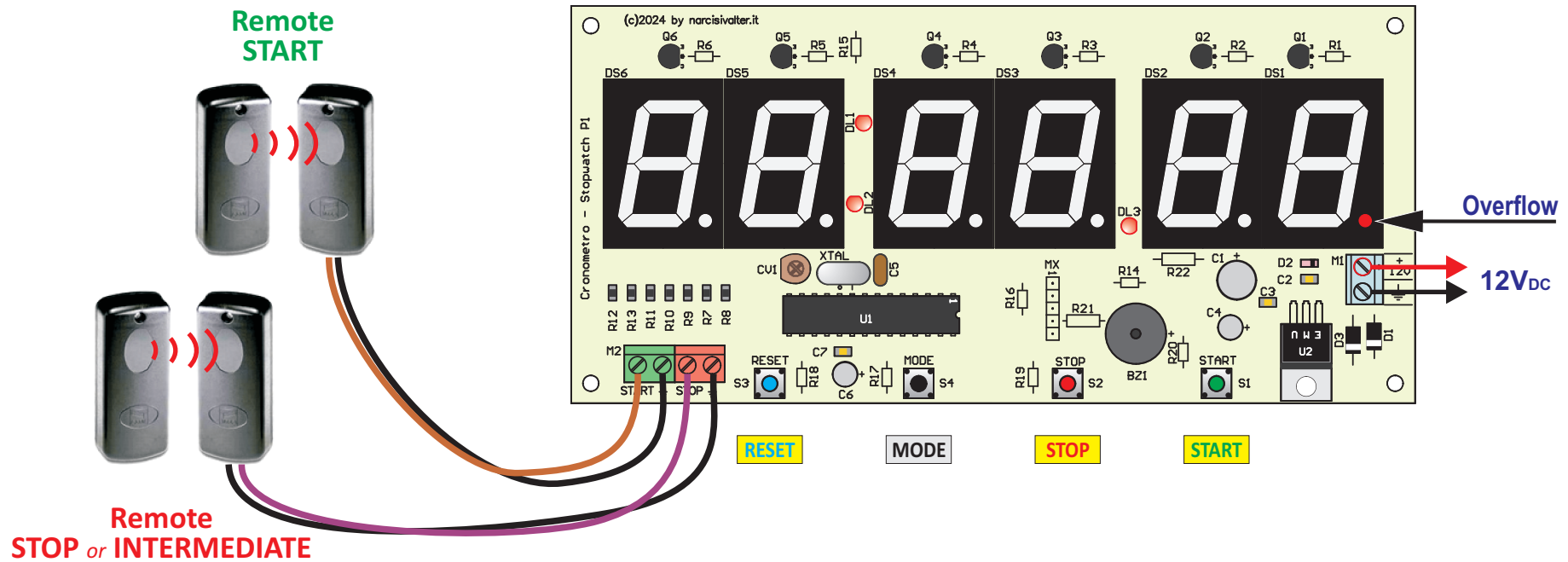

SENSORS, BUTTONS or PHOTOCELLS

Contacts must be
Normally Open - N.O.

P1 Stopwatch - SINGLE COMMAND mode

PROGRAMMING:

S = Single command for **START** and **STOP/INTERMEDIATE**

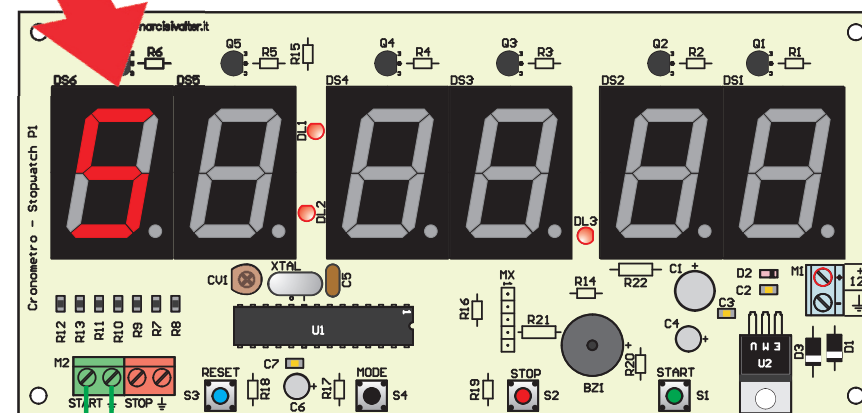
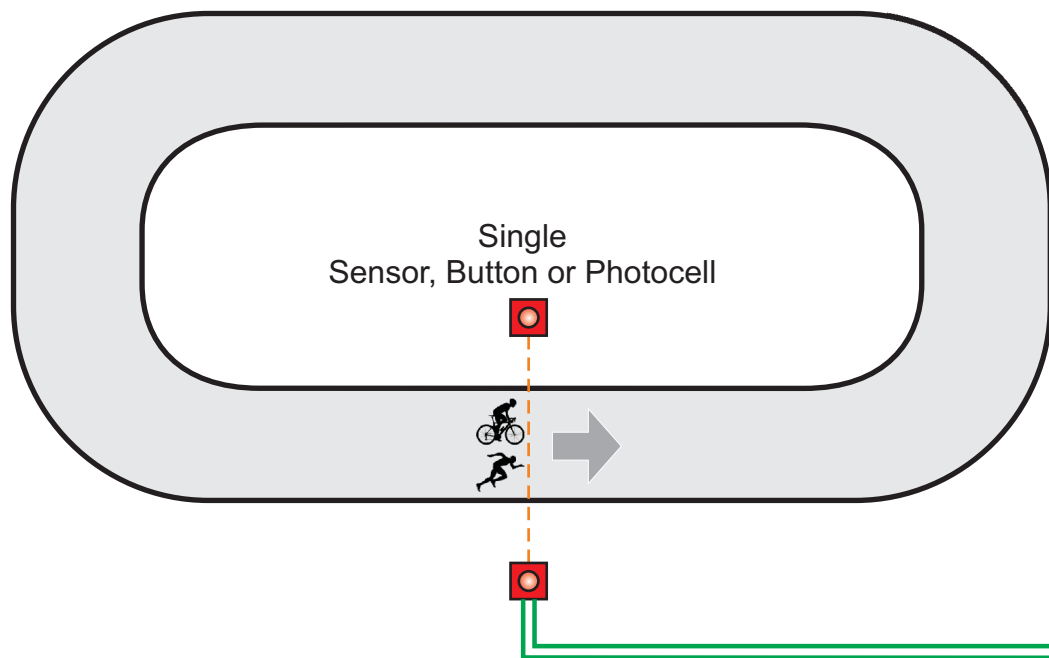

RESET MODE START

AVAILABLE COMMANDs on the BOARD

P1 Stopwatch - DOUBLE COMMAND mode

PROGRAMMING:

 = Double command: one for **START** and one for **STOP/INTERMEDIATE**

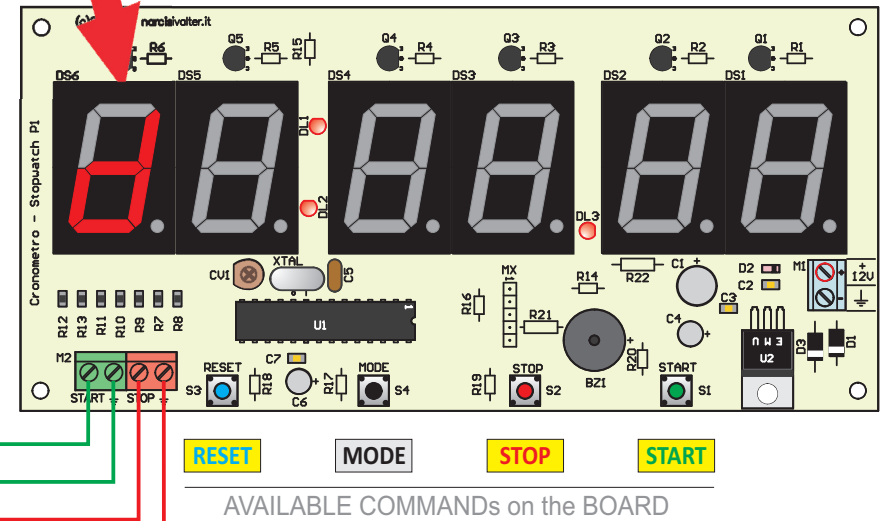
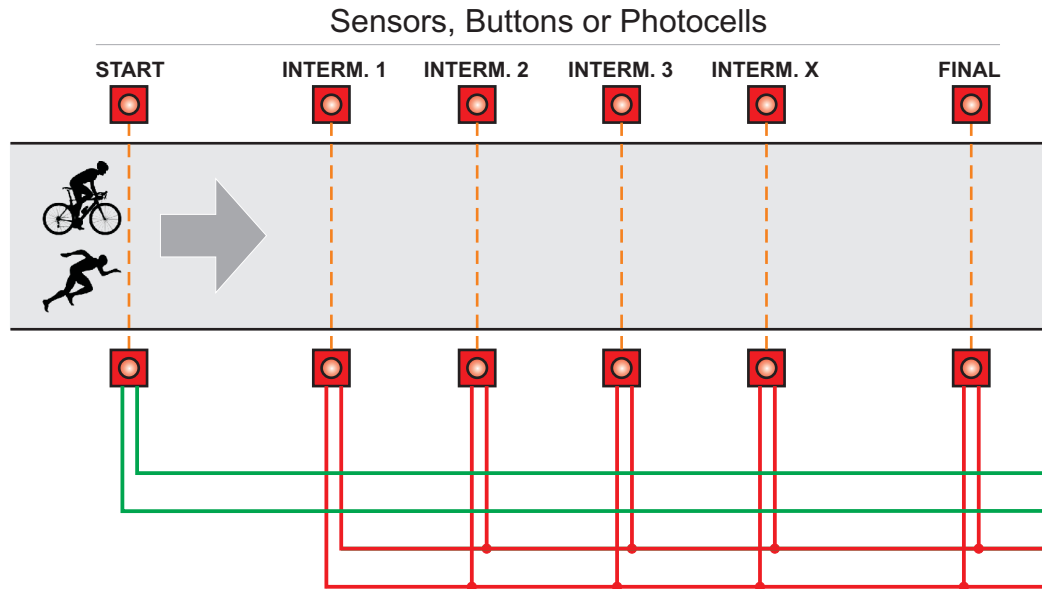

P1 Stopwatch - Wiring sample with External Buttons

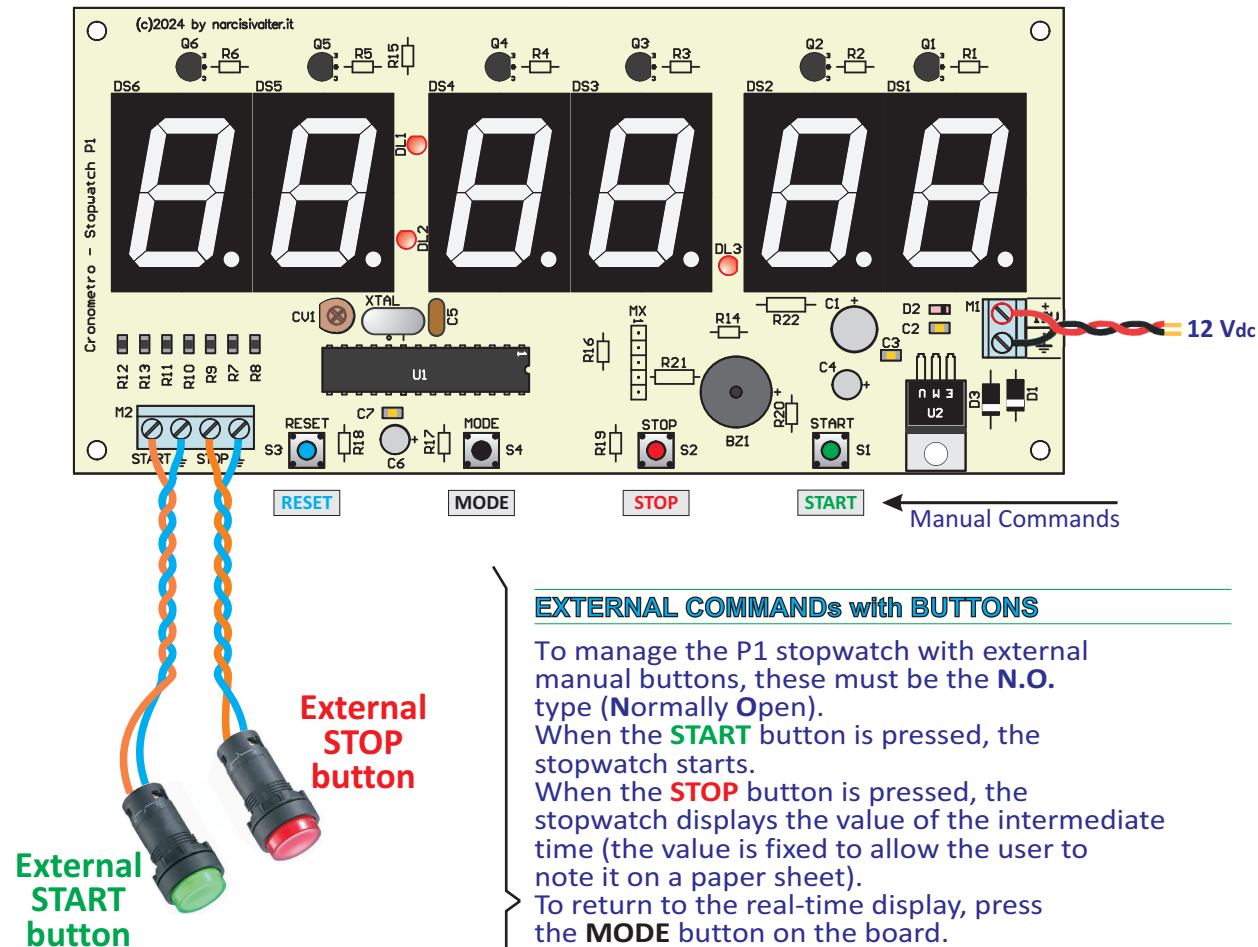

P1 Stopwatch - Wiring sample with Photocells

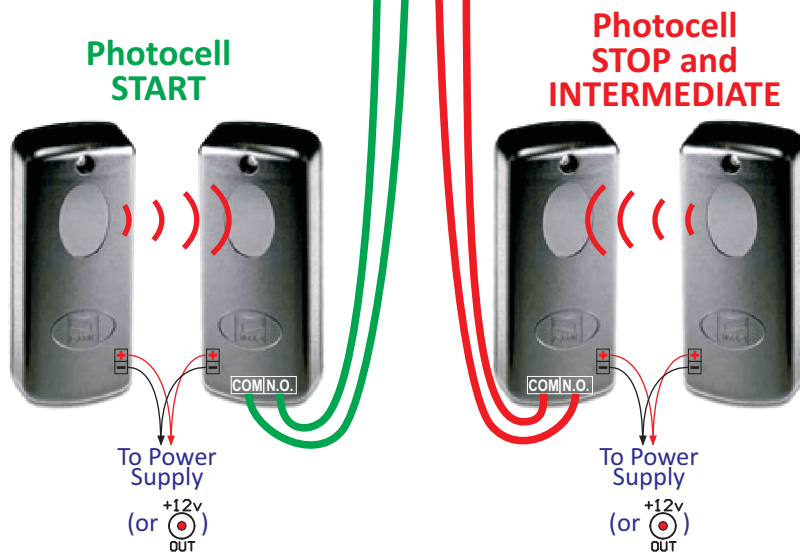
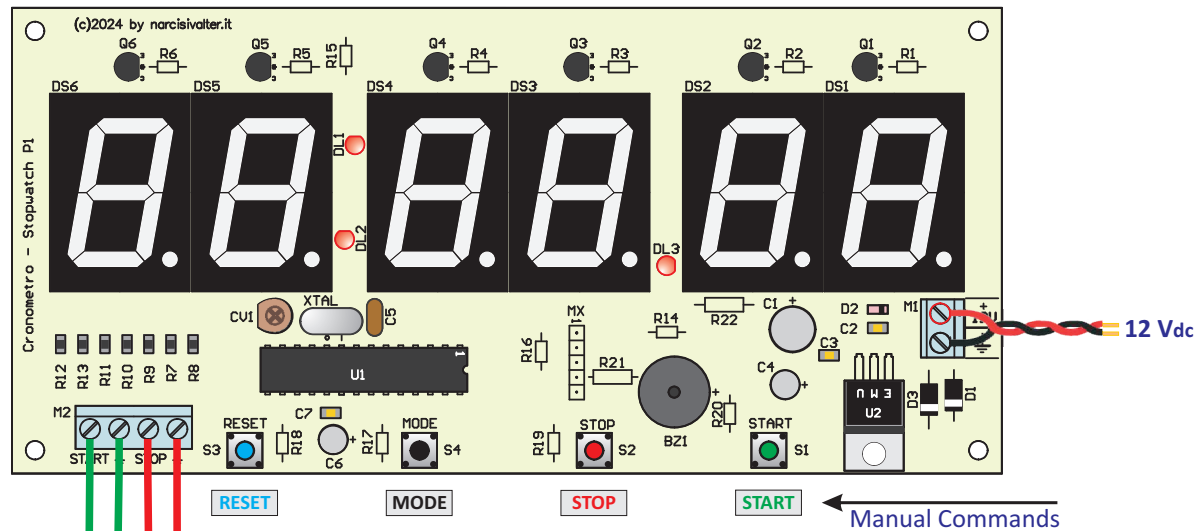

EXTERNAL COMMANDS with PHOTOCELLS

To the **START** and **STOP** terminal blocks can be applied different types of sensors and photocells (infrared, reflection, etc.)

It's most important that these photocells or sensors have three relay outputs marked **COM-NO-NC** (**COM**mon, **NO**rmaally **OP**en, **NC**losed). After centering the photocells and making sure that no object is obstructing the light beam, connect the relay outputs **COM** and **NO** to the stopwatch terminal blocks (**START** and **STOP**).

To power the photocells, use an external power source or, if they operate with 12Vdc, you can use the output on the board (marked **+12v OUT**).

NOTE - Use photocells with a low sensitivity value.

NOTE - If you use a long cable for connections, it is recommended to use a shielded cable with the metal braid to be connected to the terminal board in correspondence with the symbol $\frac{\perp}{\perp}$.

NOTE - In the "SINGLE COMMAND" mode, only the START photocell is used for both commands, so the STOP photocell can be omitted.

P1 Stopwatch - Wiring sample with OC sensors (NPN)

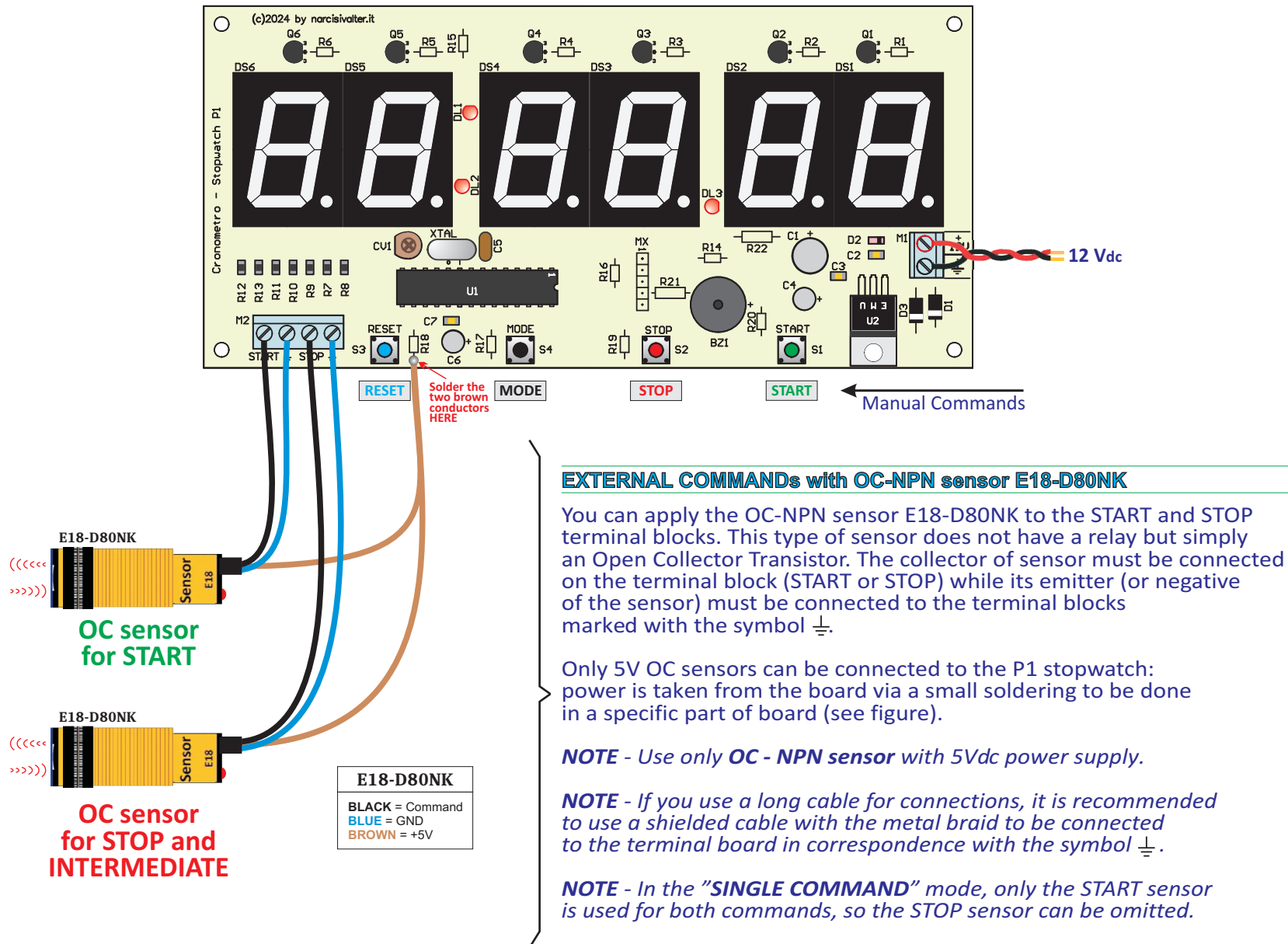

P1 - Dimensions and Holes / Dimensioni e Fori

Window for display: **160x35 mm.**
Finestra display:

Holes for installing the PCB:
Fori per il fissaggio scheda: **4 x Ø3.2 mm.**

Holes for buttons:
Fori per i pulsanti: **4 x Ø10.5 mm.**

